

*The safe, simple,
cost effective solution
to emptying bulk bags*

BAGSTANDER
BULK BAG DISCHARGER



*Striving to exceed our
customers' expectations*
ISO 9001 Certified

MADE IN CANADA

For over 30 years, UniTrak has been providing materials handling equipment for food and chemical processing companies. The Bagstander provides an economical and simple method of emptying flexible intermediate bulk containers.

The advantages of handling products and ingredients in bulk bags are numerous:

- Lower labor costs
- Lower product costs (due to buying in bulk)
- Less waste product
- Elimination of packaging waste disposal
- Cleaner and safer environment

At UniTrak we believe that operator safety is "No. 1". Our Bagstander design offers a safe and simple method of emptying your big bags.

The frame and hopper are constructed of heavy gauge steel to support the bag completely and safely.

With many special features included as standard, the UniTrak[®] Bagstander offers the best value for your bulk bag discharging needs.



Positive Loop Retention System

The loops supporting the bag cannot slip or slide off the frame, providing positive and accurate location positioning.

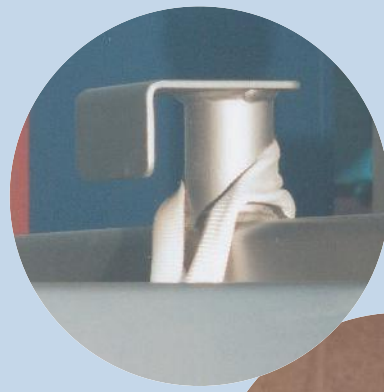

Lifting Frame Retainer

These strong stops ensure the lifting frame is maintained firmly in place on the top of the discharger frame.



Adjustable Frame

Multi-position adjustments allow bags to fit the frame. This also enables the sections to be separated for ease of shipping and installation.

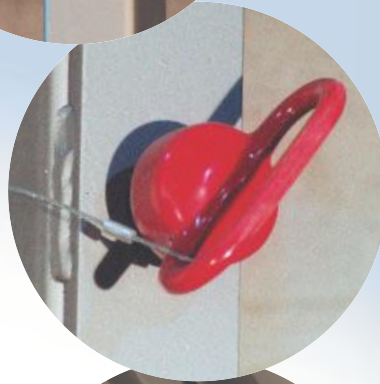

Vibrator

The factory-mounted vibrator ensures optimum bag emptying thereby eliminating waste.



Dust collection pick-up

Dust collection can be attached to side of the discharge chute, for the removal of dust and fines.



Discharge chute

The protected chute, with its dust-tight door, provides a safe environment for the operator to untie and retie the bag strings.

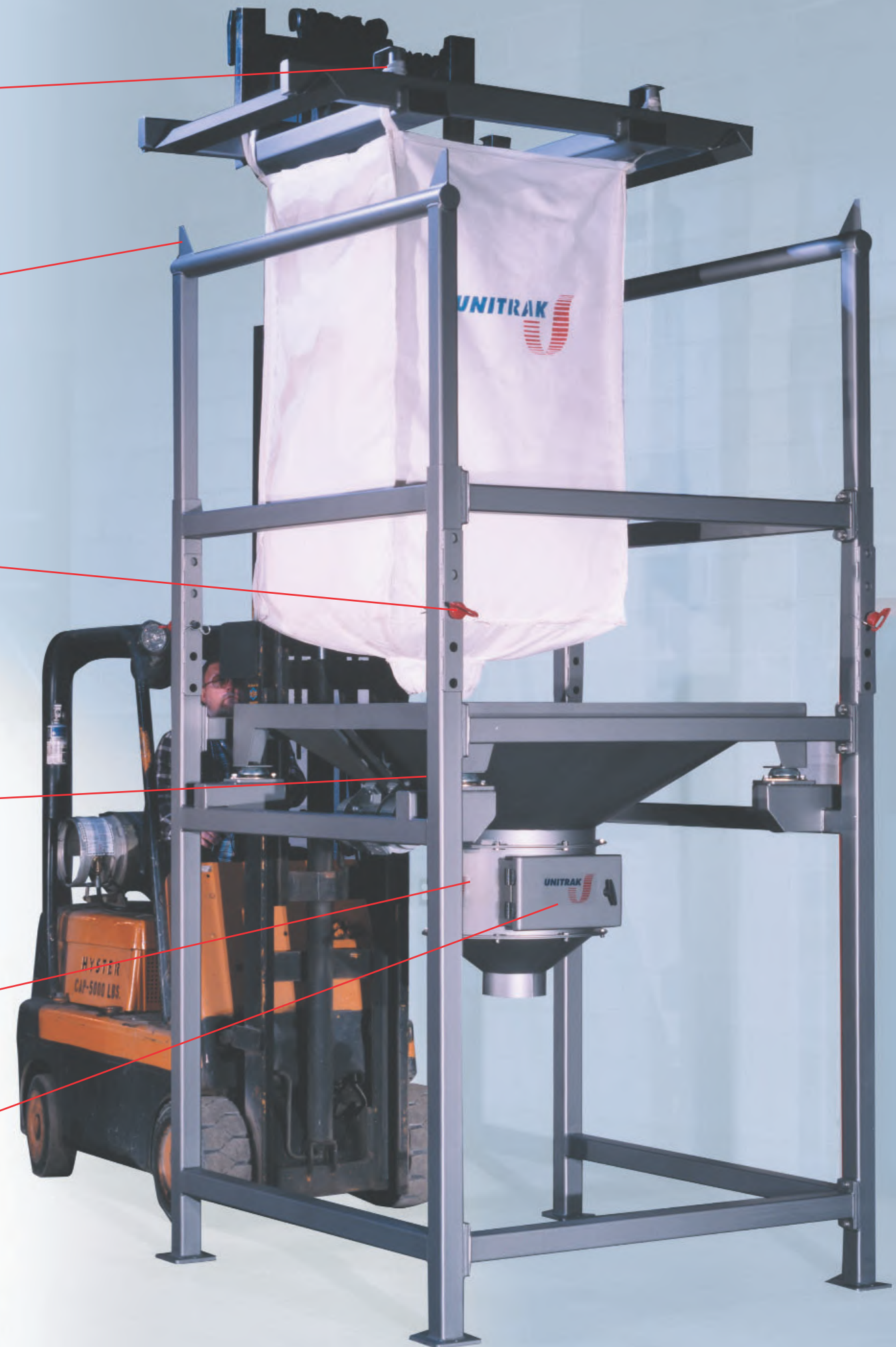

For over 30 years, UniTrak has been providing materials handling equipment for food and chemical processing companies. The Bagstander provides an economical and simple method of emptying flexible intermediate bulk containers.

The advantages of handling products and ingredients in bulk bags are numerous:

- Lower labor costs
- Lower product costs (due to buying in bulk)
- Less waste product
- Elimination of packaging waste disposal
- Cleaner and safer environment

At UniTrak we believe that operator safety is “No. 1”. Our Bagstander design offers a safe and simple method of emptying your big bags.

The frame and hopper are constructed of heavy gauge steel to support the bag completely and safely.

With many special features included as standard, the UniTrak[®] Bagstander offers the best value for your bulk bag discharging needs.

UNITRAK

*Striving to exceed our
customers' expectations*
ISO 9001 Certified



Positive Loop Retention System

The loops supporting the bag cannot slip or slide off the frame, providing positive and accurate location positioning.

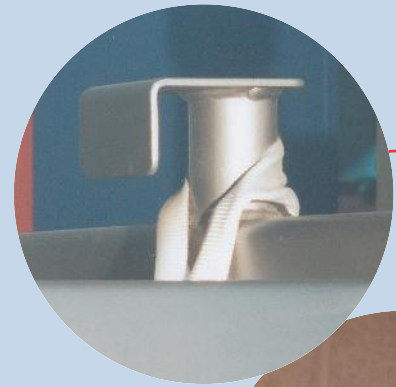

Lifting Frame Retainer

These strong stops ensure the lifting frame is maintained firmly in place on the top of the discharger frame.



Adjustable Frame

Multi-position adjustments allow bags to fit the frame. This also enables the sections to be separated for ease of shipping and installation.



Vibrator

The factory-mounted vibrator ensures optimum bag emptying thereby eliminating waste.



Dust collection pick-up

Dust collection can be attached to side of the discharge chute, for the removal of dust and fines.



Discharge chute

The protected chute, with its dust-tight door, provides a safe environment for the operator to untie and retie the bag strings.





UNITRAK

UNITRAK

HYSTER
CAP-5000 LBS.



Other Models

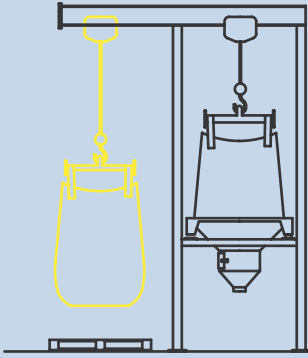

Tower Type

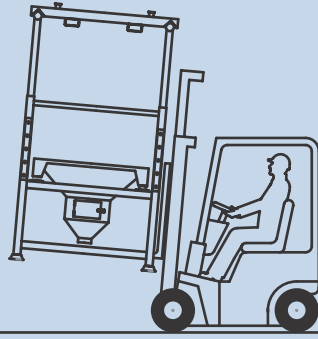

Fork Truck Loading

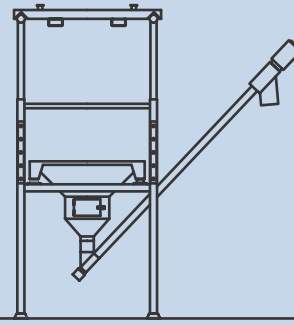

with Flexible Auger Conveyor

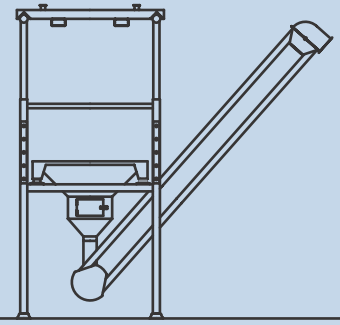

with Aeromechanical Conveyor

Examples of discharge configurations

Other products by UniTrak

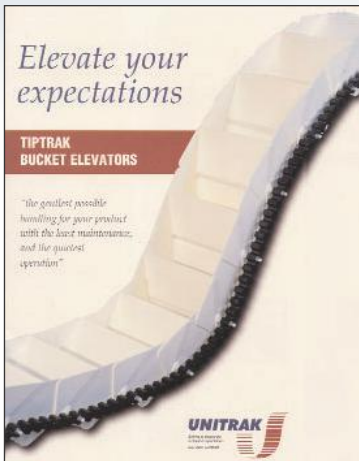

TipTrak Interlocking Bucket Elevators

TipTrak interlocking bucket elevators run horizontally, vertically or at any angle in between, eliminating transfer points, and allowing movement of product from one process to another without spillage, degradation, dusting or segregation. Corrosion resistant rubber chain ensures quiet operation, with no moving parts.



Multi Tip Pivoting Bucket Elevators

In the UniTrak® Multi Tip elevator, the pivoting buckets are uniquely centred between two strands of heavy duty, long pitch roller chain. The buckets remain upright at all times, whether moving horizontally or vertically. This pivoting feature allows for multiple discharge points and "C" configuration elevators.



UniTrak® Flexible Auger Conveyors

The UniTrak® Flexible Auger conveyors are ideal for economically conveying a wide variety of powders and granules. Easy to install! Easy to maintain! Only one moving part! The UniTrak® Flexible Auger conveyor can integrate with the Bulk Bag Discharger to provide an inexpensive solution to emptying F.I.B.C.'s.



UniTrak® Aeromechanical Conveyors

The UniTrak® Powderflight Aeromechanical conveyor consists of a continuous loop of steel cable inside two parallel tubes. Discs are attached at intervals along the cable. Material is introduced at the inlet and is propelled through the tube in pockets of air between the discs.



UniTrak Corporation Limited

P.O.Box 330, 299 Ward St.,
Port Hope, ON L1A 3W4
Canada

Tel: 905.885.8168

Fax: 905.885.2614

Toll Free: 1.877.UniTrak

Email: info@unitrak.com

Web site: www.unitrak.com